

1 foot scale on drawing border

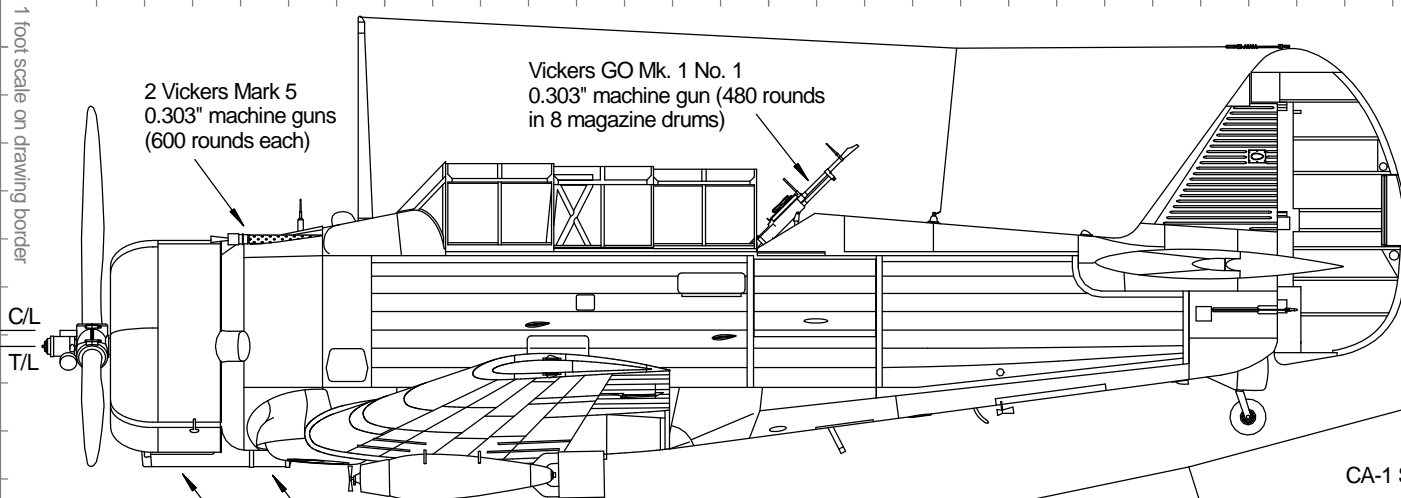

A total of 40 CA-1 Wirraway Mk I aircraft were produced by Commonwealth Aircraft Corporation from 1938 to 1940. CAC construction numbers: 1 - 40 RAAF serial numbers: A20-3 to A20-43 First aircraft delivered to RAAF: A20-4 on 20/02/1938 Last aircraft delivered to RAAF: A20-43 on 21/02/1940 CA-1 Wirraway aircraft served with the RAAF for 22 years and 2 months, the final aircraft (A20-13) struck off charge on 03/05/1960.

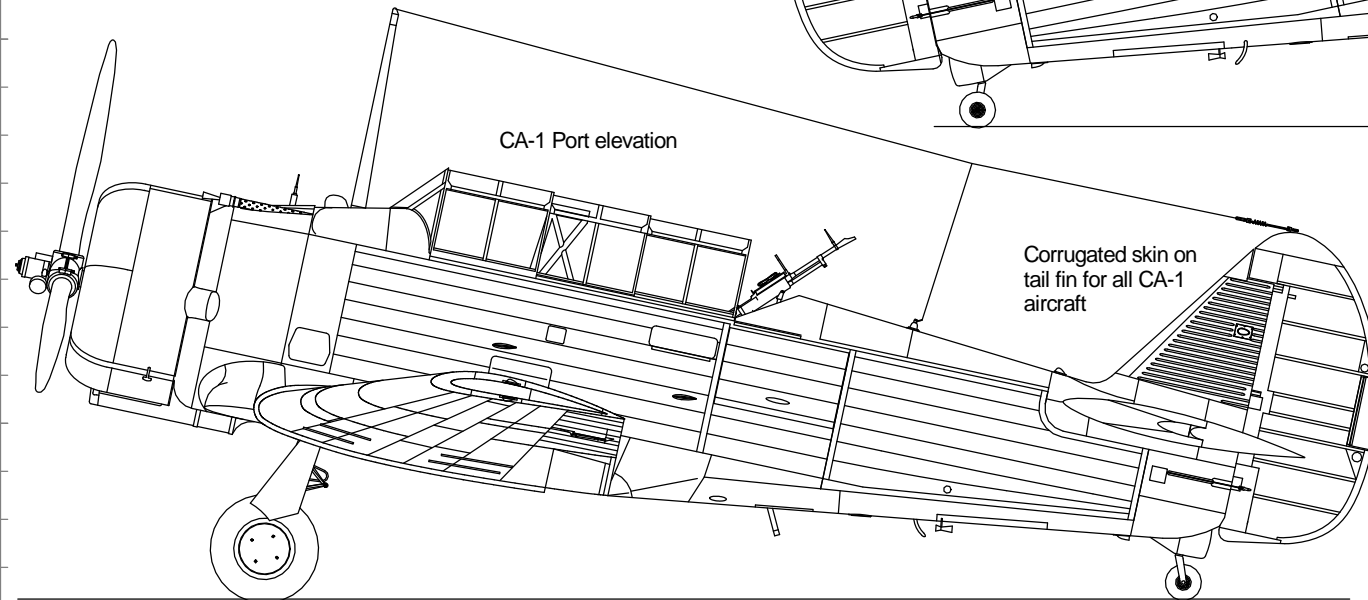
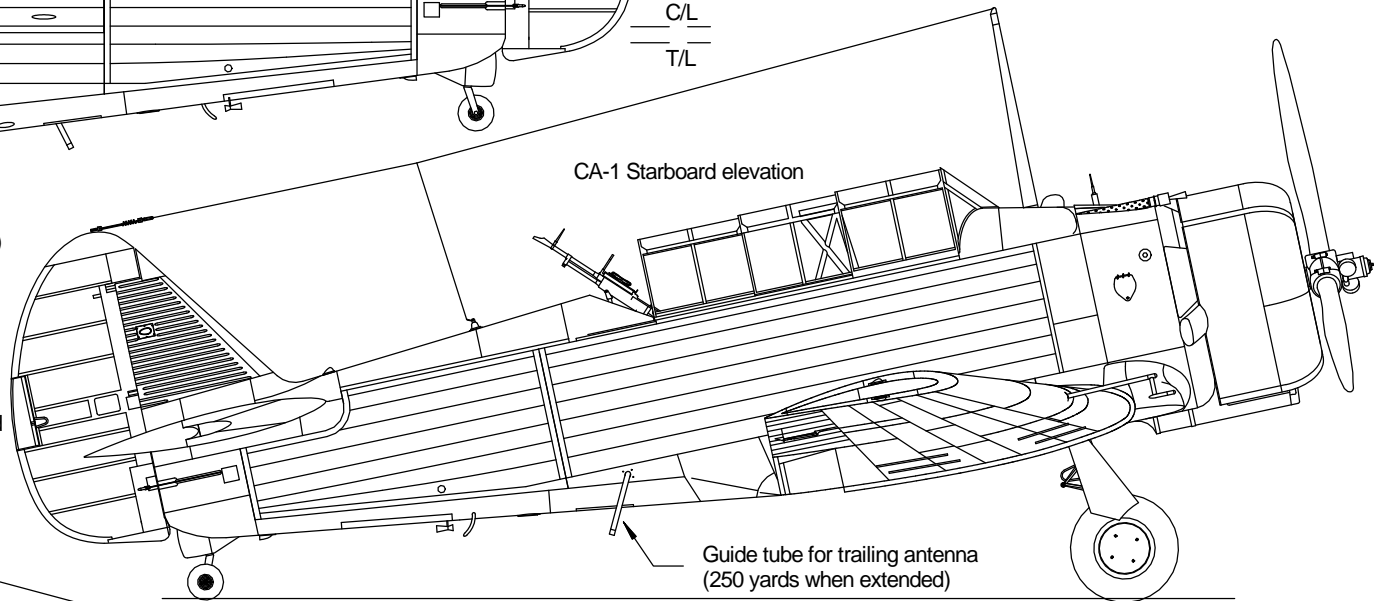
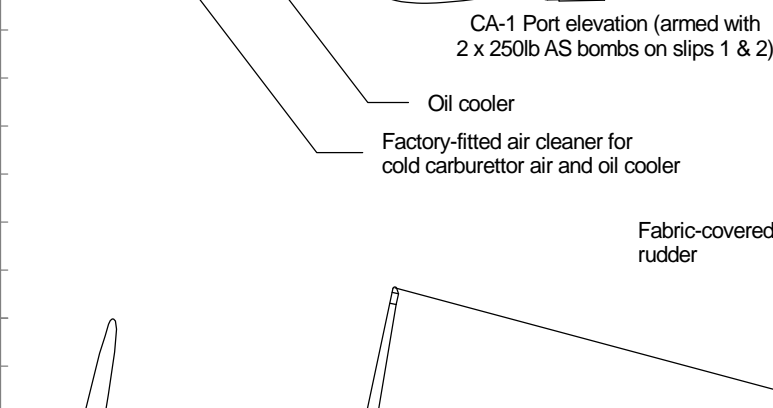

Some CA-1 aircraft were fitted with a modified air cleaner featuring an extra intake for oil cooler air

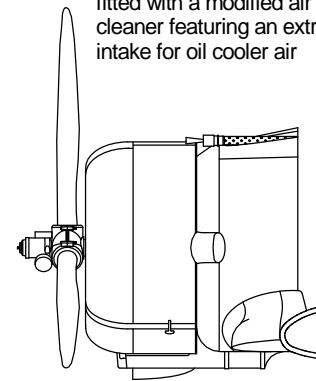

All CA-1 aircraft were progressively fitted with an improved air cleaner for cold carburettor and oil cooler air following Wirraway Order No. 108 issued 26/03/1943

