

Southern Cross Aviation Limited SC 1

Dimensions:	Prototype:	Model:	
Span:	11.28 m	520 mm	(20.5")
Length:	6.89 m	325 mm	(12.8")
Wing area:	15.9 m ²	3.28 dm ²	(50.91in ²)
Weight:	1,145 kg	28.3 g	(1.0 oz)
Wing loading:	14.75 lb/ft ²	8.6 g/dm ²	(2.8 oz/ft ²)
Power:	180 hp Lycoming	6 loops 1.6 x 300 mm	
Scale:		1 : 21.6	
Model designed by Derek Buckmaster July 1998			

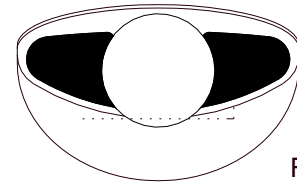

© D Buckmaster 1999

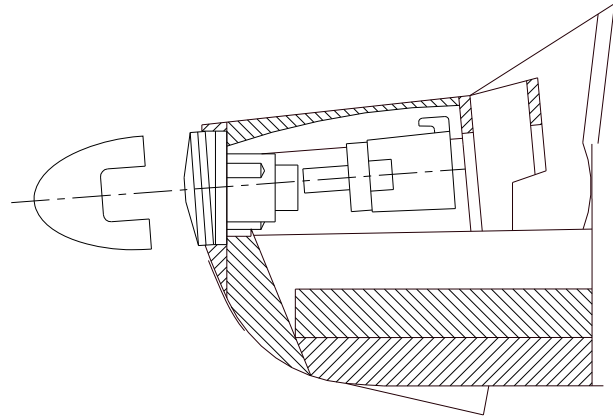
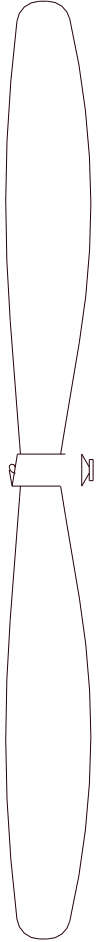
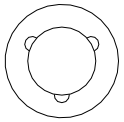

F1

