

Position of WF fillet pieces.
Sand WF and F1 1 to shape
to match contour of F3B

Fuselage framework from 2.4mm square
(shown grey). Diagonal bracing
2.4 x 1.6mm.

6" or 7" Prop

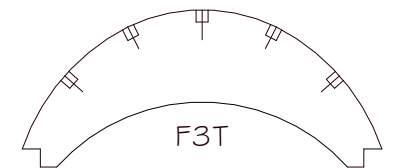

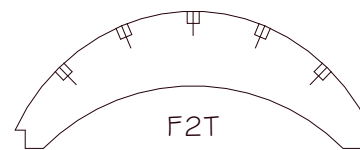
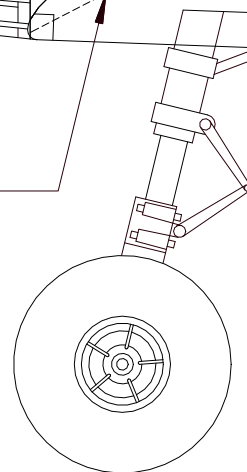
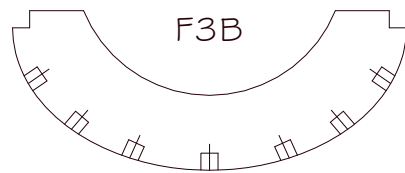
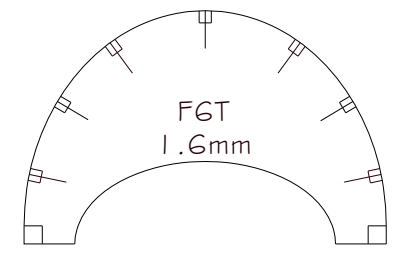
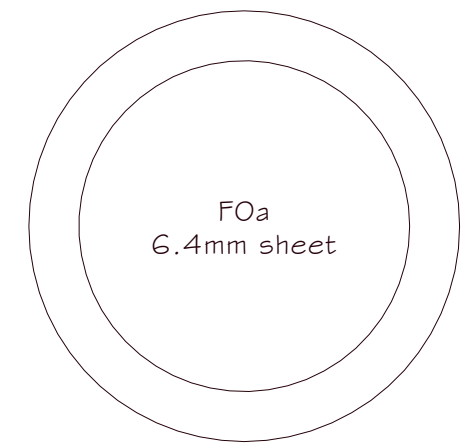
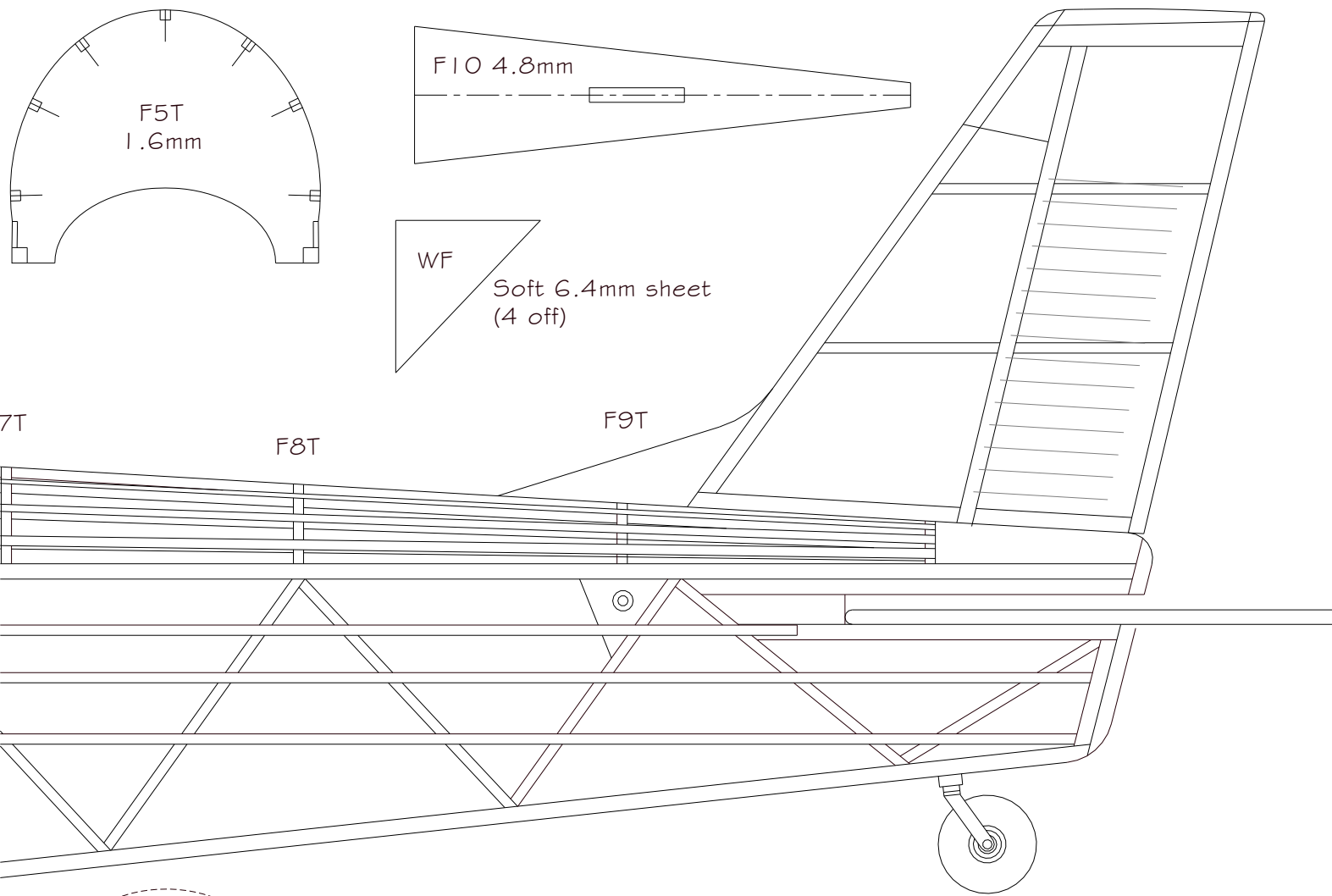

Note: This plan has **not** been test-flown yet, but is released free of charge for personal use.

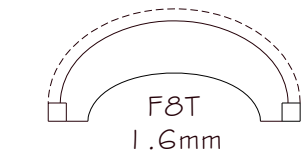

F9T
1.6mm

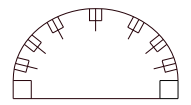

Metric conversions:

- 0.8mm 1/32"
- 1.6mm 1/16"
- 2.4mm 3/32"
- 3.2mm 1/8"
- 4.8mm 3/16"
- 6.4mm 1/4"

Sheet 5 of 6

Yeoman Aviation Cropmaster Metal Tail Testbed VH-AIV			
A rubber powered flying scale model of a 1950's Australian cropduster			
Dimensions:	Prototype:	Model:	
Span:	10.36 m	610 mm	(24")
Length:	8.08 m	443 mm	(17.5")
Wing area:	16.50 m ²	5.70 dm ²	(88.4 in ²)
Weight:	1,542 kg	70 g	(2.5 oz)
Wing loading:	19.1 lb/ft ²	12.28 g/dm ²	(4.0 oz/ft ²)
Power:	250 hp	2 loops 3.2 x 600 mm	
Scale:		1 : 17	

Model designed by
Derek Buckmaster
December 2002
© D Buckmaster 2002

Fill this section with sheet to support landing gear mounts at W1, W2 and W3

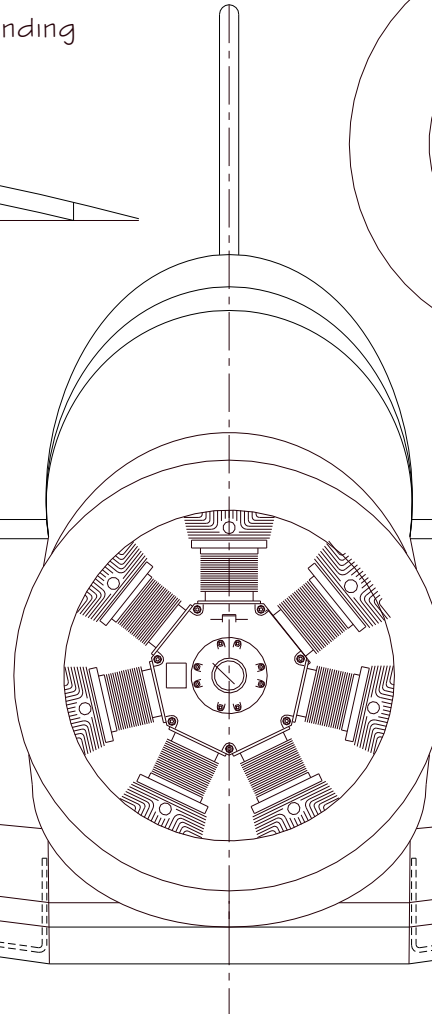
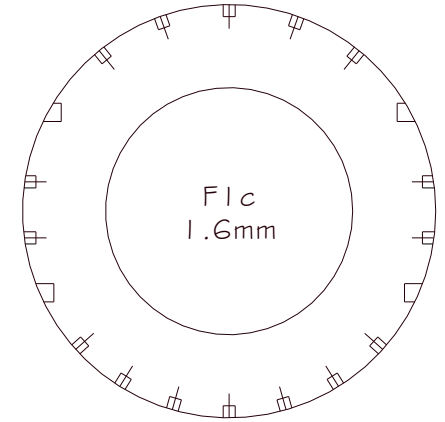
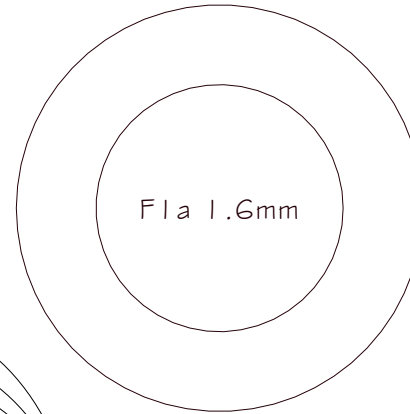
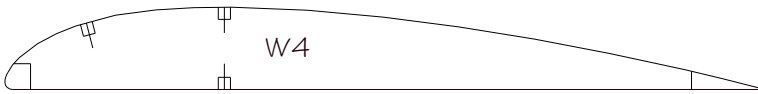

Wheel struts from 2 laminations of 3.2mm sheet (4 off)

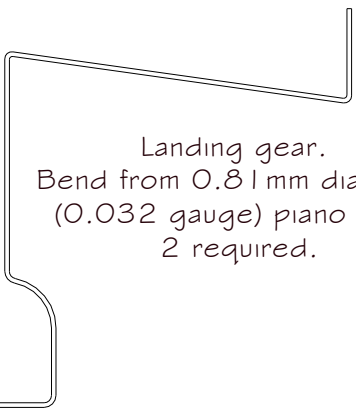

Landing gear.
Bend from 0.81 mm diameter (0.032 gauge) piano wire.
2 required.

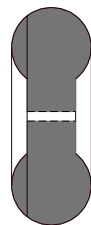
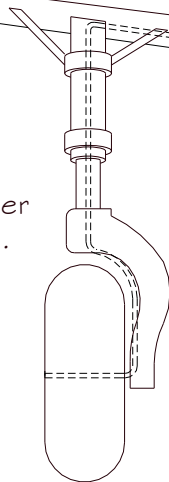

Wheels turned from sheet balsa.
Middle lamination 6.4mm, side laminations 2.4mm.
1.6mm OD aluminium tubing for bearing.

Nose construction showing
installation of Gizmo
Geezer Precision Free
Wheeler front end.

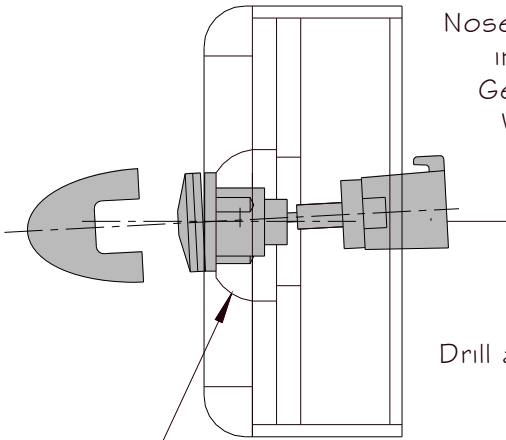

Drill a 13mm diameter
hole in FOa.

Dummy crank-
case from
4.8mm sheet

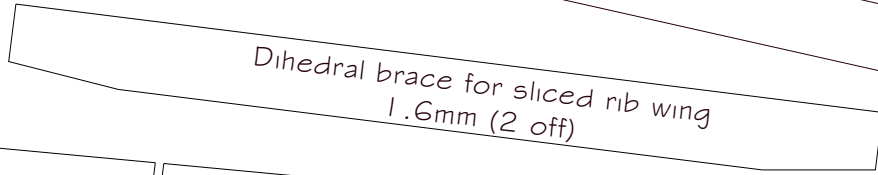
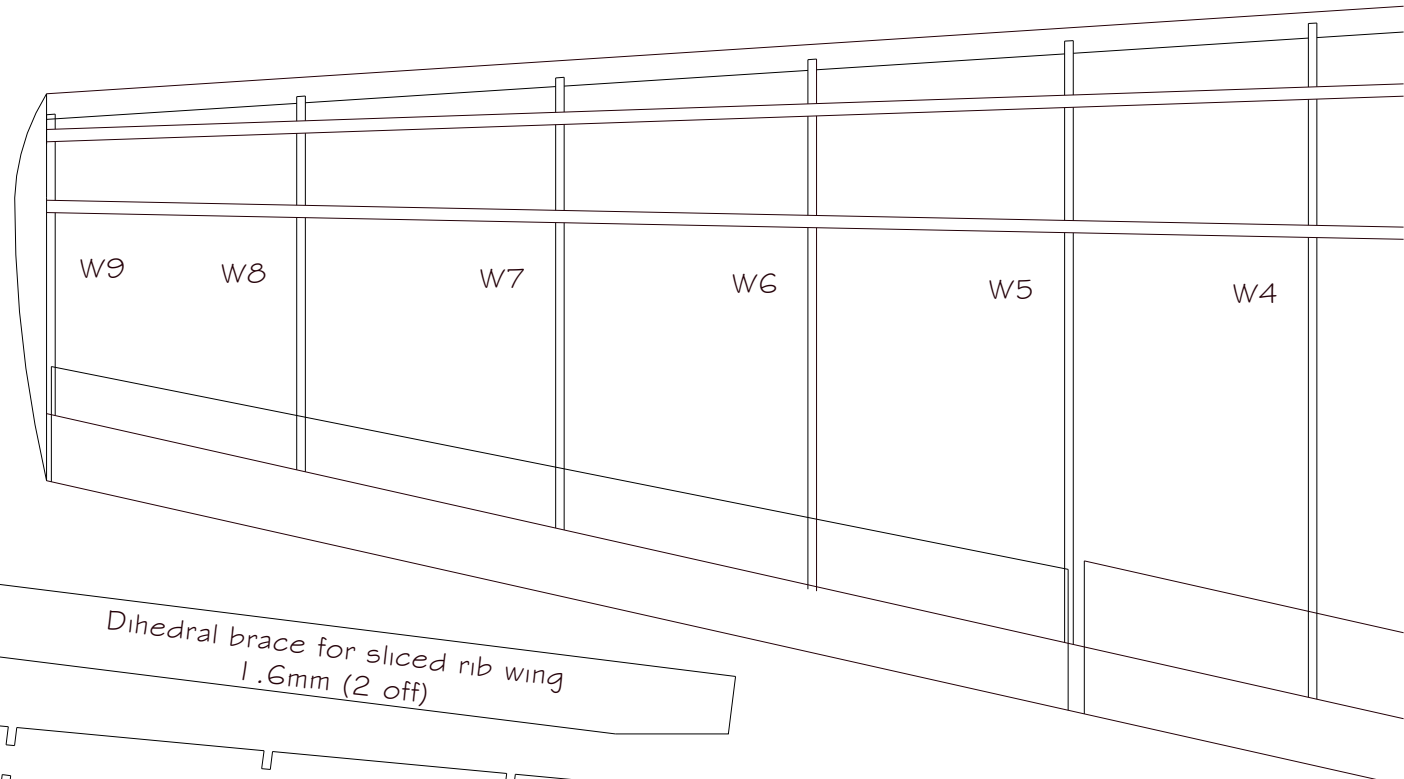
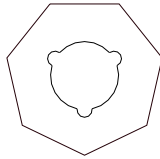

Dihedral brace for sliced rib wing
1.6mm (2 off)

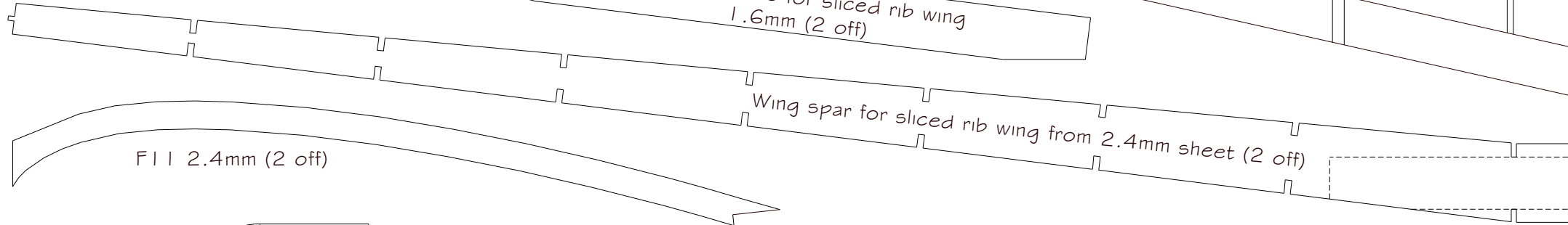

Wing spar for sliced rib wing from 2.4mm sheet (2 off)

F11 2.4mm (2 off)

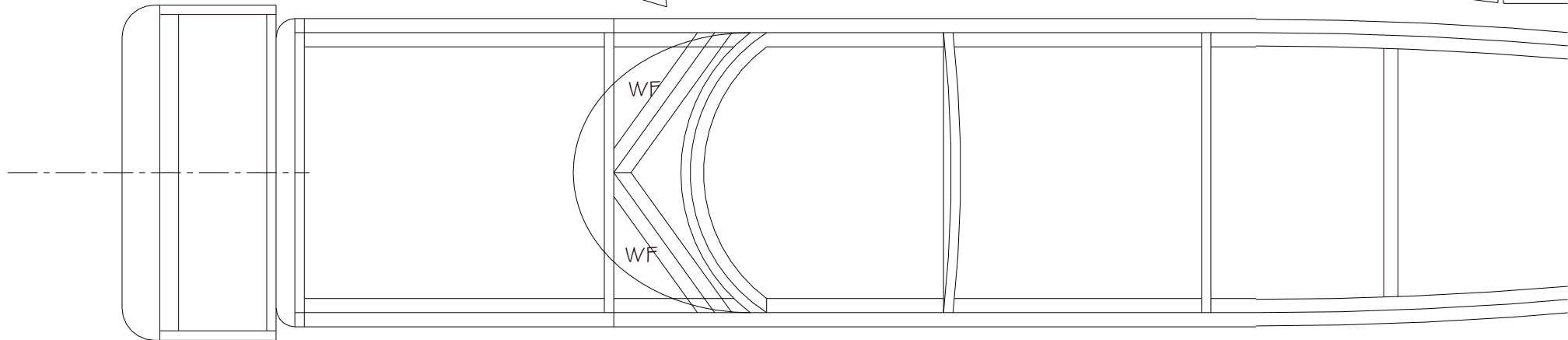

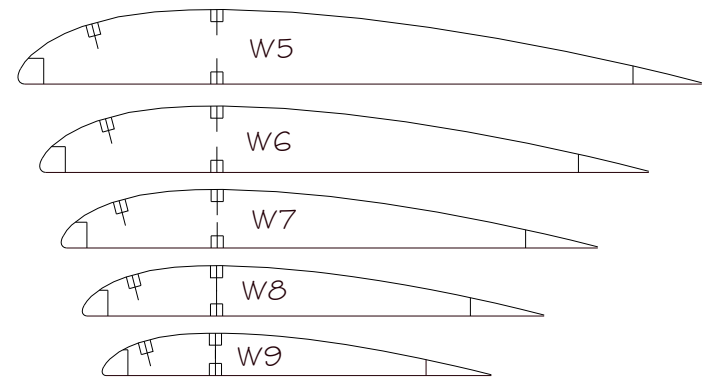
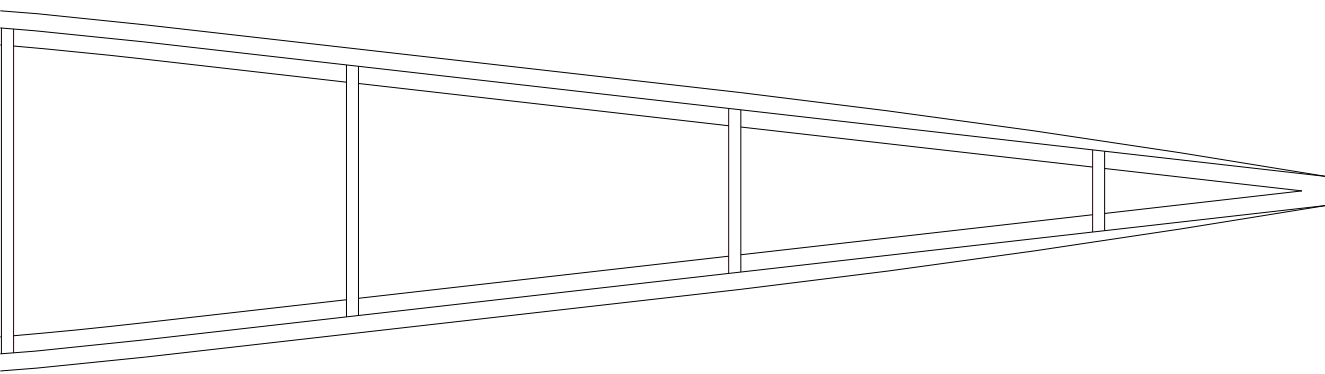
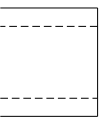
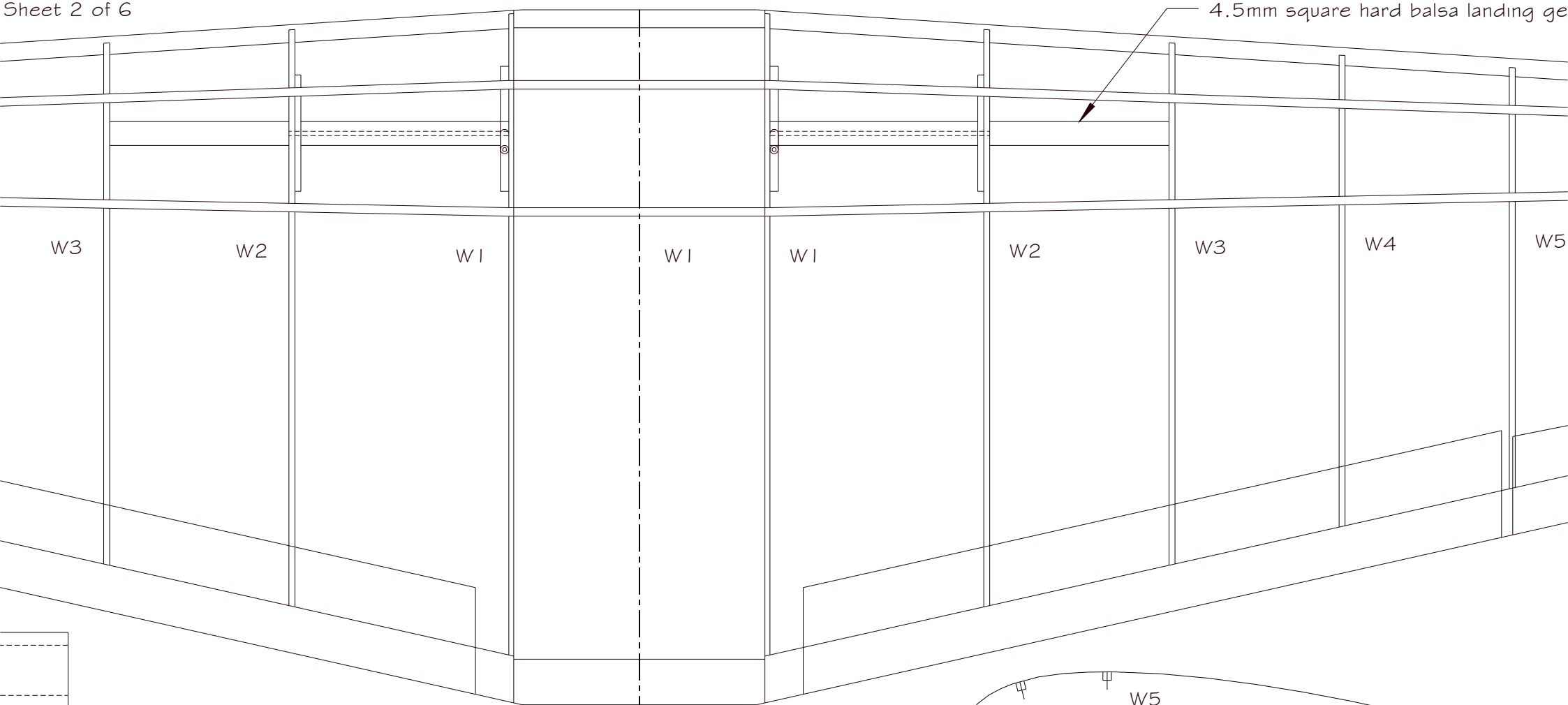

All wing ribs from 1.6mm sheet

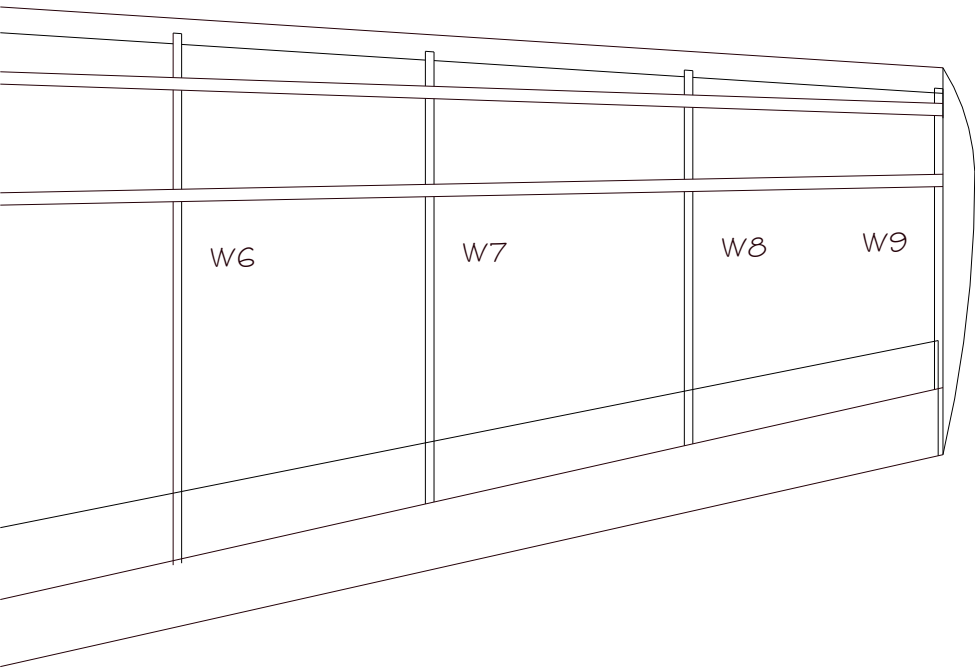

Dummy crank-case
4.8mm sheet

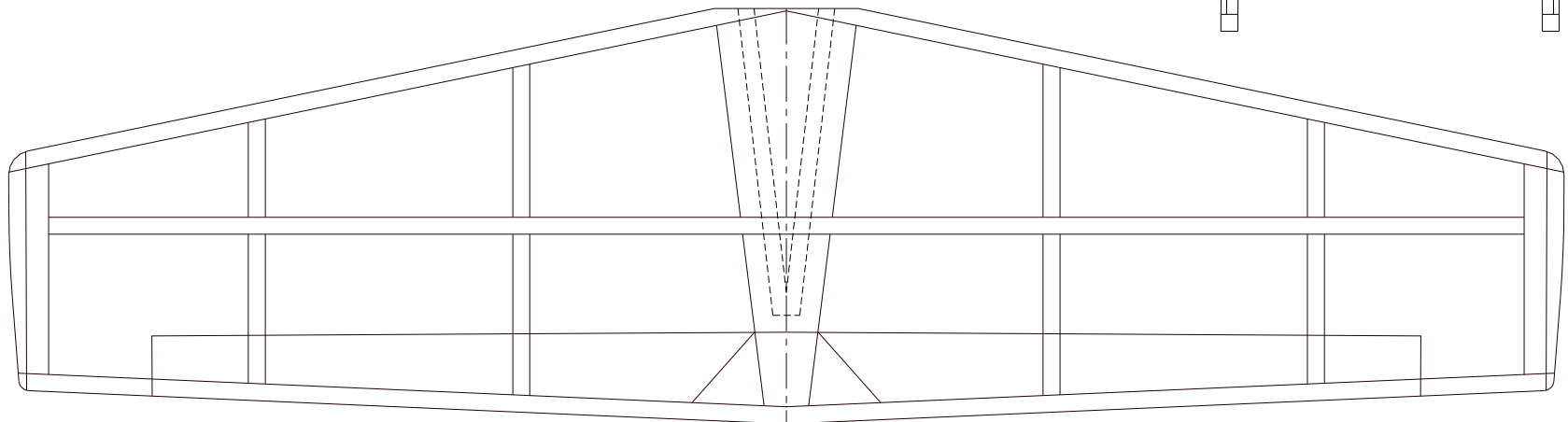
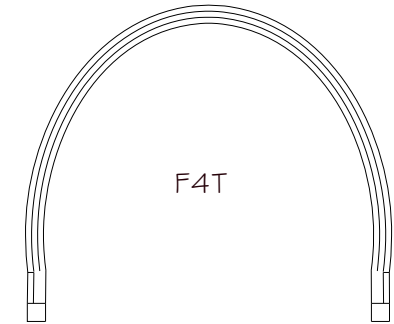
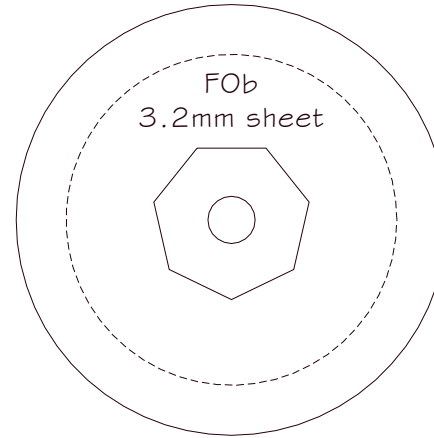
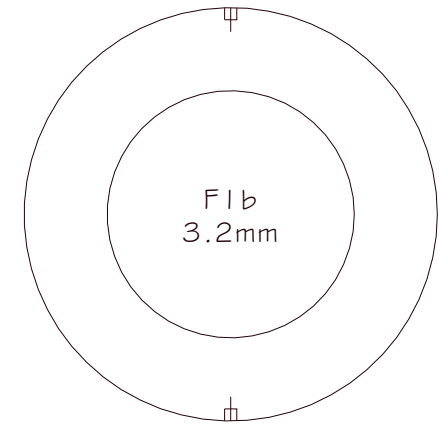
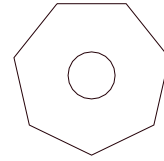

Template for sliced wing ribs 1.6mm.
Trim from rear to match chord at each
rib location.

Tail plane constructed
from 2.4mm square strip
and 2.4mm sheet